

Make your business fly!



Best erosion protecting with ERCoat^{nt}



MTU Aero Engines GmbH
Dachauer Straße 665
80995 Munich • Germany
Tel. +49 89 1489-0
Fax +49 89 1489-5500
E-mail karin.wolf@mtu.de
www.mtu-aero-solutions.com

GER 05/09/MUC/01000/DE/EB/E

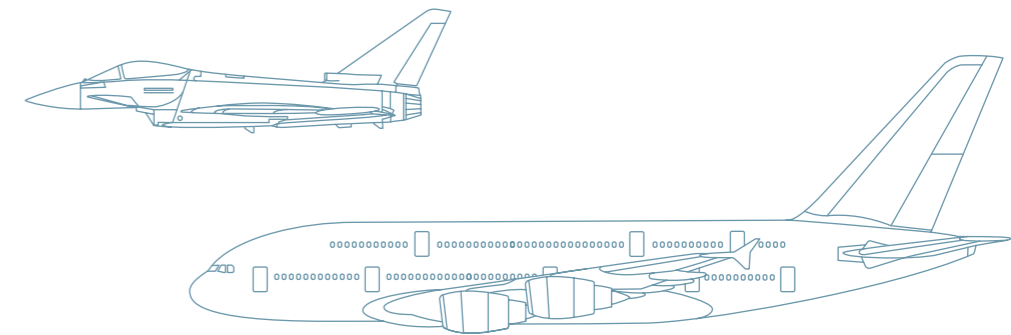

The challenge

Being a brand of Germany's leading engine manufacturer, MTU Aero Solutions can draw on nearly 100 years of aircraft engine background. MTU Aero Engines ranks among the global players in the industry being a leader in major engine areas.

The "million euro" grains of sand

Damage to engine components due to erosion by sand and other particles results in enormous costs. The consequences of erosion: strikingly short times between shop visits, reduced lives of the affected components and increased fuel consumption.

Rising to the challenge and ensuring continuous development leads to the solution of nanotechnology which supports ERCoat^{nt}

- coating parts of various geometry and size
- coating titanium-, nickel- and steel-alloys
- application of soft and hard layer
- application of single- and multilayer

ERCoat^{nt} properties:

- Up to tenfold life improvement
- Coating thickness customized to your part
- Base material properties unchanged
- Remaining High Cycle Fatigue (HCF) strength >85 %
- Frequency change negligible
- Foreign object damage & notches can be blended
- Low Cycle Fatigue (LCF) strength of coated blades sufficient to accommodate even stall and surge events
- Long term oxidation stability up to 650 °C
- Short term oxidation stability up to 750 °C

Your benefit

Our leading technology for your outstanding performance

Advantages:

- longer time on wing
- reduced maintenance material cost
- lower logistics expenses
- increased engine availability
- improved flight safety
- less unscheduled engine removals
- reduced scrap rate
- less fuel consumption, resulting in reduced CO₂ emissions

The ERCoat^{nt} approvals:

EASA and FAA
Multiple patents pending

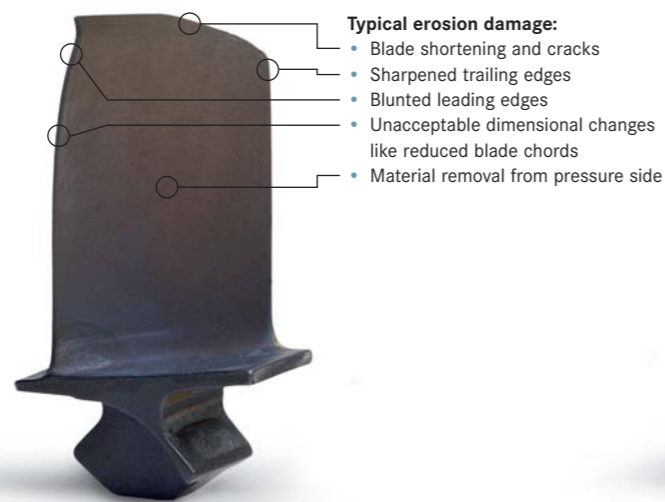
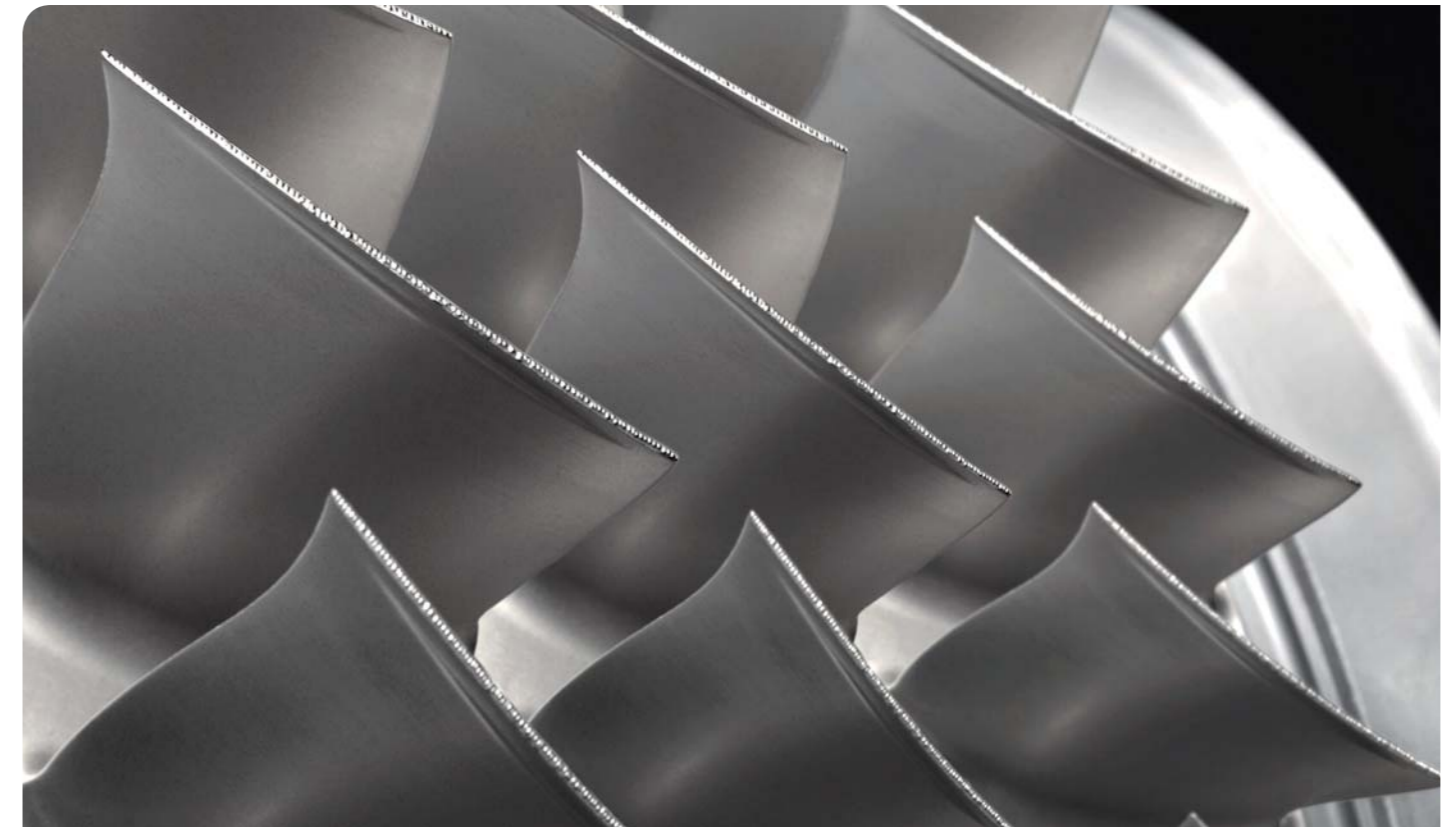

Damaged blade



Virgin blade

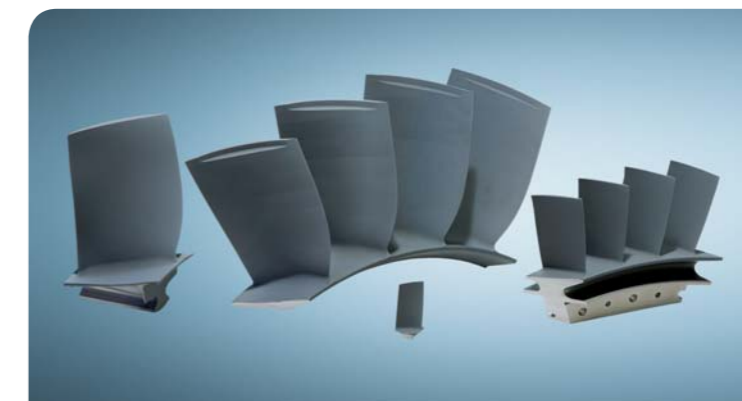

One blade like the other – secured by ERCoat^{nt}.

Latest generation high temperature ERCoat^{nt} on different types of airfoils with improved properties.