



Commercial parts repair

MTU Maintenance, the largest independent provider of commercial engine maintenance, repair and overhaul (MRO) services, is also a global leader in repair technology. Following its motto “repair beats replacement” MTU focuses on repairing parts rather than replacing. Development of unique and cutting-edge technologies and its marketing to engine MRO clients as well as third party repair customers, represents central aspects of MTU’s strategy. Customers benefit from both MTU’s OEM knowledge and its customer-oriented MRO service approach. Proprietary repairs are marketed as MTU^{Plus} repairs and provide customers with single source high technology DER approved repairs that ensure longer on-wing times and durability. MTU Maintenance provides seamless global services in which individual customers benefit from low turnaround times, broad capabilities and reliable service at optimum costs.



MTU Maintenance potential

MTU Maintenance will still repair where others have long resorted to replacement, preserving the part value by salvaging material that would normally be scrapped according to engine manual practices. Furthermore, parts remain fully repairable at subsequent shop visits, resulting in considerable cost savings versus purchasing new parts. MTU Maintenance offers a wide variety of repairs ranging from accessories and combustors to hot section blades and vanes.

V2500-A1 / -A5 / -D5, HPC drum, stages 3-8 – damper wire groove plasma repair

An MTU^{Plus} repair solution

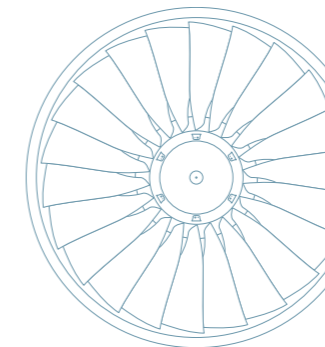

An MTU Aero Engines Company

MTU Maintenance Hannover GmbH
Münchener Straße 31
30855 Langenhagen • Germany

Marketing & Sales Component Repair
Tel. +49 511 7806-9042
Fax +49 511 7806-603
E-mail partsrepair@haj.mtu.de

The MTU^{Plus} repair solution

As a technological leader in research and development as well as a major manufacturing company for modules and components, MTU lends its OEM experience and technical knowledge to develop new and alternative repair processes. MTU^{Plus} branded technologies are proprietary in-house developed repair processes which guarantee excellence in repair solutions. MTU^{Plus} repair processes increase lifespan and value of the part by salvaging material, thus also allowing for future repairs at subsequent shop visits. Additionally, MTU^{Plus} repair processes provide improved part performance and as a result, longer engine service life is expected. Outstanding performance of repaired parts outlines MTU Maintenance's motto: repair beats replacement.

The MTU^{Plus} advantage

Innovative technologies, outstanding quality, reliability and service have made MTU Maintenance a dependable partner for more than 25 years—worldwide. MTU^{Plus} repair processes stand for superior and unique repair solutions:

- wide variety, high-tech repair portfolio
- world-class in-house parts repair development combined with OEM know-how
- EASA & FAA DER approved repairs
- highest standard of quality
- independent, cost-effective solutions
- improved processes and repair yields
- high durability and performance of parts
- low turnaround time

Repair background

More than 50 HPC drums stages 3-8 were measured and analyzed to investigate why part rejection was occurring due to wear at the damper wire groove. The analysis revealed it was possible to successfully restore the damper wire groove with MTU's plasma spray. Extensive studies and testing, such as stress analysis, LCF testing, spinning rig testing and bond testing proved the repair with superior results. With world class technology, MTU is now a single source, DER approved repair provider for worn damper wire groove.



Repair process

HPC drums with wear at the damper wire groove are repaired using MTU's proprietary plasma spraying process. After dimensional inspection, the groove is machined and the plasma spray is applied. Final dimensional machining occurs prior to final inspection.



Plasma spray is applied to restore the damper wire groove.



Part in restored condition.

Repair benefits

The customer can benefit from this damper wire groove repair with a 28 calendar day turnaround time and substantial cost savings versus purchasing new parts. As a result of this repair, part life is extended.

