

PurePower™ PW1000G Engine

This Changes Everything™

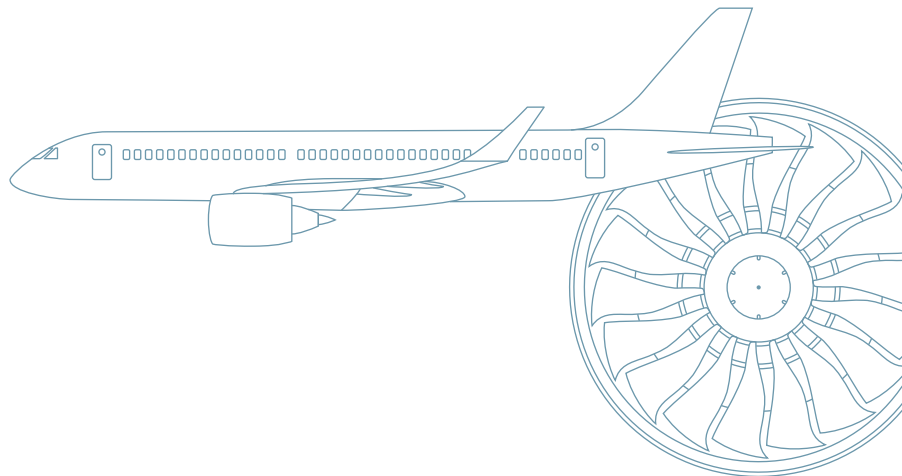

PurePower™ PW1000G – technology features

The PurePower™ engine family is Pratt & Whitney's new family of next-generation commercial and business jet engines that offers double-digit improvements in fuel burn, environmental emissions, engine noise and operating costs. The first commercial engine to enter service will be the PurePower™ PW1000G engine. It uses an advanced gear system allowing the engine's fan to operate at a speed different from that of the low-pressure compressor and turbine.

To date, the PW1000G has been selected by Mitsubishi Aircraft Corporation for its next-generation Mitsubishi Regional Jet (MRJ), by Bombardier for its all new CSeries aircraft and by Irkut as well as by Airbus for their latest single-aisle developments MS-21 and A320neo. In case of MRJ and CSeries the PW1000G is the exclusive powerplant.

The PW1000G will enter service with Bombardier's CSeries in 2013. The MRJ will follow one year later (2014). MS-21 and A320neo are scheduled for 2016.

MTU Aero Engines is Germany's leading engine manufacturer. The company's share in the PW1000G engine is 15 percent. MTU holds design and manufacturing responsibility for the forward stages of the high-pressure compressor and for the high-speed low-pressure turbine (LPT).

The forward stages of the eight-stage high-pressure compressor consist of blisks in a novel Titanium material for maximum performance and durability. Advanced coating systems ensure best-in-class performance. The three-stage LPT is designed for high-speed operation. Each stage incorporates advanced 3D aerodynamic airfoils for improved engine operating efficiency. Aerodynamic optimization between the mid-turbine frame (MTF) and the LPT permitted the first-stage vane to be eliminated to reduce part count and engine weight without sacrificing efficiency.

Key features:

- 10K to 40K thrust range (initial product focus)
- 12 - 15 percent reduction in fuel burn over current engines for single-aisle aircraft
- Noise levels 15-20 dB below Stage 4 limits
- 55 percent reduction in NO_x emissions over 2009 standard (CAEP 6)
- Engine operating cost reduced by more than 20 percent

Engine models:

- PW1215G/PW1217G
- PW1521G/PW1524G
- PW1124G/PW1127G/PW1133G
- PW1400G

Aircraft powered by the PurePower™ PW1000G Engine:

- Bombardier CSeries (exclusive powerplant)
- Mitsubishi Regional Jet MRJ (exclusive powerplant)
- Airbus A320neo
- Irkut MS-21

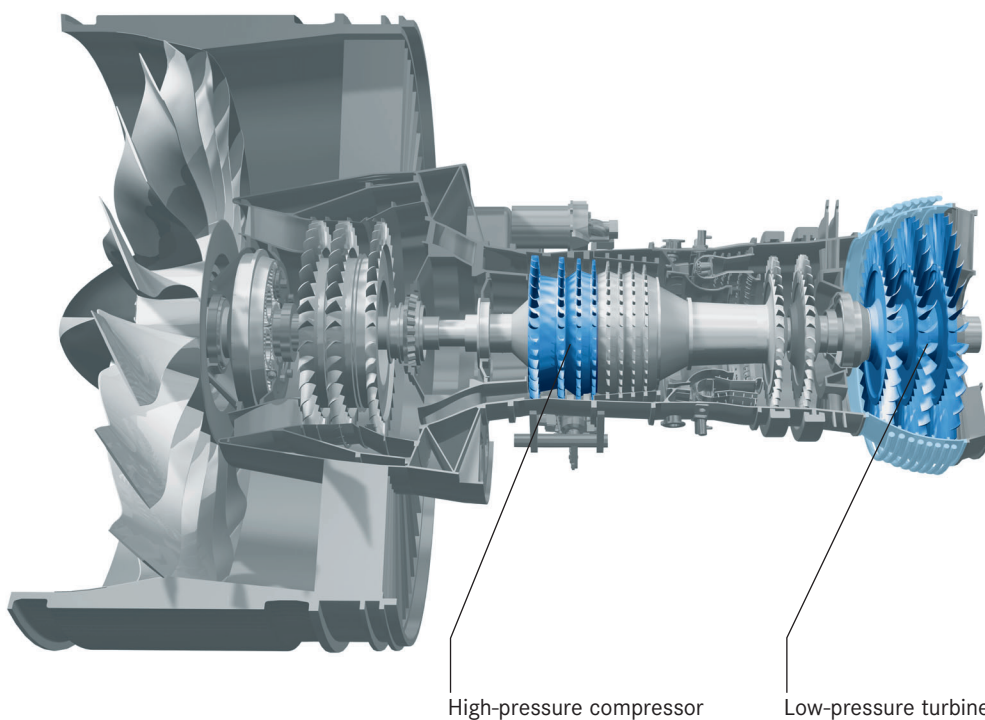

PurePower™ PW1000G Engine Family Product Specifications	PW1215G/ PW1217G	PW1521G/ PW1524G	PW1124G/ PW1127G/ PW1133G	PW1400G
Thrust (lbs.)	15-17K	21-23K	24-33K	24-33K
Fuel Burn (vs. current engines)	-12-15 %	-12-15 %	-15 %	-15 %
Noise (vs. stage 4)	-15 dB	-20 dB	-20 dB	-20 dB
Emissions-CO ₂ reduction per a/c (tonnes annually)	-2,700	-3,000	-3,600	-3,600
Emissions-NO _x (margin to CAEP 6)	-50 %	-55 %	-55 %	-55 %
Fan diameter (inches)	56	73	81	81
Stage count	1-G-2-8-2-3	1-G-3-8-2-3	1-G-3-8-2-3	1-G-3-8-2-3
Applications	MRJ	CSeries	A320neo	MS-21
Entry into service	2014	2013	spring 2016	2016



MTU Aero Engines GmbH
Dachauer Straße 665
80995 Munich • Germany
Tel. +49 89 1489-0
Fax +49 89 1489-5500
info@mtu.de
www.mtu.de